

BD14W

WHEEL DOZER



Salient Features :

- Turbo charged BS6D105-1 BEML engine
- Electronic Transmission
- Articulated Power steering
- Limited slip differential
- Center point articulation
- Better Tractive effort



BD14W

Blade Capacity	: 2.4m ³
Gross Power	: 110 kW(148 HP) @ 2000 r/min
Fly Wheel Horse Power (Net)	: 94kW(126 HP) @ 2000 r/min
Operating Mass	: 15000 kg

www.bemlindia.in

BD14W

WHEEL DOZER

Salient Features :

Sturdy direct injection type, turbo charged BEML Diesel Engine for sustained power and fuel economy.

Articulated power steering for higher maneuverability and faster cycles.

Limited slip differential front and rear axles for positive traction while loading.

Rear axle oscillation offers stability to the machine on rough and uneven terrains.

Centre point articulation for safer steering operation. The rear wheels always track the front wheels.

Neutral starter switch in the circuit to avoid engine starting when transmission gear shift lever is not in neutral.

Greater drawbar pull and faster cycle time for higher production.



ENGINE

Make	BEML LTD.
Model	BS6D105-1
Type	Water cooled 4 cycle, over head valve, direct injection type, turbo charged diesel engine.
No. of Cylinders	6
Bore & Stroke	∅ 105 x 125 mm
Displacement	6.5 ℓ (6,499 cc)

HORSE POWER

Gross Power	110 kW(148 HP) @ 2000 rpm
Net Power	94 kW(126 HP)@ 2000 rpm(As per ISO:9249)
Maximum Torque	565 Nm (58 kgm) @ 1400 rpm

FUEL SYSTEM

Type	BOSCH Inline FIP system
Governor	Mechanical, all speed control

LUBRICATION SYSTEM

Method	Gear pump, forced lubrication
Cooler	Water cooled

ELECTRICALS

Starting Method	Electric
Starting Motor	24V, 4.5kW
Alternator	24V, 45A
Battery	24V (2x12V), 150 Ah

TRANSMISSION

TORQUE CONVERTER

Model	W340
Type	Hydrodynamic
Stall Ratio	3.095 : 1

Transmission

Model	4WG190 ERGO POWER
Type	Rear mounted multi speed power shift electronic control transmission with four forward & three reverse speeds
Controls	Manual Range Selector

AXLES & FINAL DRIVE

Type	Front axle is fixed, and Rear axle oscillates up Or down by 10°, (total 20°) for greater machine stability.
------	---

Final Drive

Type	Four wheel drive, full floating with planetary reduction in each wheel.
------	---

Travel Speeds

Forward km/h (m/s)	Reverse km/h (m/s)
1st 6.28 (1.74)	1st 6.61(1.84)
2nd 11.66 (3.24)	2nd 12.24 (3.4)
3rd 21.43 (5.95)	3rd 22.34 (6.2)
4th 31.4 (8.72)	---

STANDARD ACCESSORIES

Ammeter, Engine oil pressure gauge, Water temperature gauge, Transmission oil temperature gauge, Engine hour meter, Horn, Starter key switch, Working and traveling lights, Foot Throttle, Fenders, Starting motor, Alternator, Regulator, Batteries, Canopy, Reverse light and alarm, Side indicator lamps, Fire extinguisher, Tool box, Brake and Tail lamp, Battery charging indicator, High beam indicator, Parking brake applied indicator, Low air pressure warning.

OPTIONAL ACCESSORIES

Steel Cabin
Tyre Inflation Kit
Pre heater



HYDRAULIC SYSTEM

Pump Type	Vane Pump
Capacity	176 litres/min @ 2000 rpm
Relief Pressure	13.73 MPa (140 kg/cm ²)
Control Valve Type	Double spool type
Positions	
Lift System	Raise, Hold, Lower and Float
Bore x Stoke	∅ 90 x 883 mm - 2 No.



FILTRATION

Engine	Replaceable micro paper element filter for lubrication as well as for fuel line is provided.
Transmission	Replaceable element type of filter is provided.
Hydraulic System	Magnetic plug and replaceable element type filter is provided.



STEERING SYSTEM

Type	Articulated, full power steering 25° on either side.
------	--

Steering Pump

Type	Vane Pump
Flow	176 l/min @ 2000 rpm
Relief Valve Setting Pressure	12.25 MPa (125 kg/cm ²)
Turning Radius	7200 mm (Minimum)
Bore x Stoke	∅ 90 x 535 mm - 2 No.



TYRES AND RIMS

Tyres

Standard	18.00 x 25-24 PR, L-4 (Tube less)
----------	-----------------------------------

Rims

Type	Flange type
Size	13.00 x 25
Max. gradeability	25% (~14°)



DIMENSIONS mm

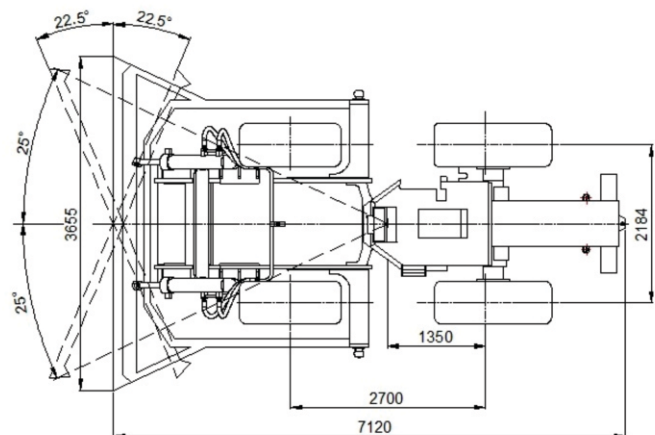
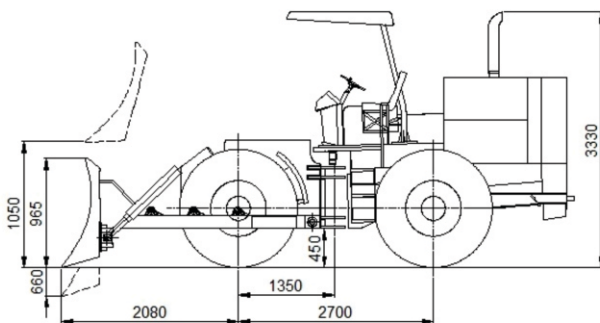

TOP VIEW



SERVICE CAPACITIES

System	(litres)
Cooling system	45
Fuel tank	185
Crank case engine	25
Transmission (inclusive of drop box)	27
Front axle	35
Rear axle	35
Brake oil tank	2.4
Hydraulic tank	195



COOLING SYSTEM

Radiator	Continuous finned flat tube de-aeration type tank
Pump	Centrifugal pump
Fan	Blower type
Air cleaner Type	Dry, 2-stage, horizontal
Air Compressor	
Capacity	160 CC



BRAKES

Service Brakes	Wet multiple disc type. Air over Hydraulic actuated.
Parking Brake	Disc type, spring applied and hydraulic released operating pressure @ 126 kg/cm ² .



BLADE

Type	Angling & tilting
Mass (kg)	1645
Digging angle	55°
Blade angle	25.5°
Blade length x height (mm)	3655 x 965
Max. lift above ground (mm)	1050
Max. drop below ground (mm)	660
Max. tilting adjustment (mm)	400
Blade capacity	2.4m ³



OPERATING MASS

Operating mass	15,000 kg approx.
----------------	-------------------

Material and specifications are subject to change without notice, Illustrations may include optional equipment & accessories

BD14W

WHEEL DOZER

TECHNICAL SPECIFICATIONS

बी ई एम एल लिमिटेड BEML LIMITED

Schedule 'A' Company under Ministry of Defence, Govt. of India

Business Network

Corporate Office

BEML Soudha, 23/1, 4th Main,
S.R. Nagar, Bangalore – 560 027

T + 91 80 22963240, 22963250

F + 91 80 22963278/516/280/164

E-mail: office.cpd@beml.co.in
corpcomm@beml.co.in

International Business Division

Flat No. E,F,G, H, 'Vandana' 11th Floor,
11, Tolstoy Marg, Connaught Place
New Delhi – 110 001

T + 91 11 23316500

F + 91 11 23325085

E-mail: mx@beml.co.in

Marketing Division

5th Floor, Unity Building,
J.C. Road, Bangalore – 560 002

T + 91 80 22963501/02/07/510/540

F + 91 80 22963541

E-mail: m@beml.co.in
mmd@beml.co.in

REGIONAL OFFICES

Bangalore

4th Floor, Unity Building, J. C. Road,
Bangalore - 560 002
Karnataka

T + 91 97413 51588

E-mail: mg@beml.co.in

Bilaspur

1-A, Industrial Area, Sector-C, Sirgitti,
Bilaspur - 495 223.
Chhattisgarh

T + 91 7752 252745, 252598

F + 91 7752 252065

E-mail: mv@beml.co.in

Neyveli

F-4, Dr. Rajendraprasad Road,
Block-27, Neyveli, - 607 803
Tamil Nadu

T/F + 91 4142 268517

T + 91 4142 265517 / 229392

E-mail: ma@beml.co.in

Dhanbad

Mouza - Kangalo, Amaghata,
Govindpur.KG Ashram Post, Dhanbad
Jharkhand – 828 109

T + 91 94711 92023

E-mail: mf@beml.co.in

Hyderabad

3-6-114, Street No.18, Himayat Nagar,
Hyderabad - 500 029
Telangana

T + 91 40 2322 7032 / 94907 93117

F + 91 40 23221794

E-mail: rm.hyderabad@beml.co.in

Kolkata

35/1A, Taratala Road,
Kolkata - 700 088.
West Bengal

T + 91 33 2401 5286 / 87 / 98 / 99

F + 91 33 2401 5288

E-mail: rm.kolkata@beml.co.in

Mumbai

32A, Bazar Road,
Near Jain Mandir, Bandra (West), Mumbai,
Maharashtra - 400 050

T + 91 22 26431875 / 26435875

F + 91 22 26423928

E-mail: rm.mumbai@beml.co.in

Nagpur

No 33, Cement Road,
Shivaji Nagar,
Nagpur - 440 010, Maharashtra.

T + 91 712 2248435 / 2248343

F + 91 712 2249997

E-mail: mn@beml.co.in

New Delhi

Flat E,F,G,H, 'Vandana', 11th Floor,
11, Tolstoy Marg, Connaught Place,
New Delhi - 110 001

T + 91 11 2344 3511 / 3528 / 2331 6500

F + 91 11 2332 5085

E-mail: ml@beml.co.in

Ranchi

206/D-1, Bhagirathi, (Behind NCC Campus)
Rameshwaram Colony, Bariatu Road,
Ranchi, Jharkhand - 834 009

T + 91 651 2540710 / 94311 08531

E-mail: mr@beml.co.in

Sambalpur

BEML Complex, NH-6, Panchagachhia,
Baraipalli Post, Sambalpur 768 006
Odisha.

T + 91 663 2521604 / 2521389

E-mail: mb@beml.co.in

Singrauli

PB No. 5, Jhingurdha Colliery,
Singrauli - 486 889
Madhya Pradesh.

T + 91 7805 272668 / 272318

F + 91 7805 272282

E-mail: rm.singrauli@beml.co.in

ACTIVITY CENTRES

Bhopal

Ground Floor, Hall No.1, Chittod Complex, Zone-1,
Maharanapratap Nagar (MP Nagar), Bhopal - 462 011

T + 91 755 2550711 / 8989459753

Panjim

BEML Limited, 5/4, Victor Building, Fontanhas, Mala,
Panjim - 403 001, Goa

T + 91 832 2225135 / 77986 87178

Itanagar

C/o. Tobom Riba, H-Sector, Papum
Itanagar – 791 113, Arunachal Pradesh

T + 91 94029 34205 / 88372 15852

Kochi

No. 39/2122, Chittoor Road, Emakulam South,
Kochi – 682 016

T + 91 484 2375138

E-mail: rm.kochi@beml.co.in

Maihar

Maihar, Madhya Pradesh

Mob: +91 79875 53768

Silapathar: Surya Vatika, Amritpur, Silapathar, Assam - 787 059 T + 91 95311 29059

DISTRICT OFFICES

Ahmedabad

99/100, BEML HOUSE, 2nd Street,
Azad Society, Ambawadi,
Ahmedabad - 380 015, Gujarat

T + 91 79 26445523 / 94264 13620

F + 91 79 26423950

E-mail: rm.ahmedabad@beml.co.in

Asansol

3, Bumpur Road,
Asansol - 713 304
West Bengal

T + 91 341 2252480

F + 91 341 2250601

E-mail: mca@beml.co.in

Bacheli

Behind Central Stores of NMDC Ltd.,
Depot 5, Bacheli - 494 553.
Chhattisgarh

T/F + 91 7857 230005

E-mail: rm.bacheli@beml.co.in

Bhilai

Room no 22/C, BSP Expansion Building,
Near Ispat Bhavan, Bhilai 490 001, Chhattisgarh

T + 91 788 2223880

F + 91 788 2221652

E-mail: mnb@beml.co.in

Bhubaneswar

252/A, Lewis Road
Bhubaneswar - 751 014
Odisha

T + 91 674 2434427 / 99373 83950

E-mail: mbb@beml.co.in

Chandrapur

Mamidwar, Tiles Factory Compound
Ghugus Road, Padoli
Chandrapur - 442 406 Maharashtra

T + 91 7172 287230

F + 91 7172 287560

E-mail: mnc@beml.co.in

Chennai

Flat No. 10, Supriya Estates,
No.3, Sterling Road, Nungambakkam,
Chennai - 600 034, Tamil Nadu,

T + 91 44 28220844

F + 91 44 28257319

E-mail: rm.chennai@beml.co.in

Guwahati

No.11, Ward 43, Hengrabari Road,
Ganesh Puri, Dispur,
Guwahati - 781 006 Assam

T + 91 361 2232966

F + 91 361 2232967

E-mail: rm.guwahati@beml.co.in

Hospet

No.1431, Manjunatha Complex,
Bhagat Singh Nagar, Opp. KSSIDC Indl. Estate,
Dam Road, Hospet - 583 203, Karnataka

T/F + 91 8394 230172

E-mail: rm.hospet@beml.co.in

Jammu

62C, Block D/C, Gandhi Nagar,
Jammu tawi - 180 004
Jammu and Kashmir

T + 91 191 2459 437

F + 91 191 2430 447

E-mail: mlj@beml.co.in

Kothagudem

Old Project Planning Department,
Near SCCL Corporate Office,
Kothagudem - 507 101, Telangana

T + 91 8744 245572

F + 91 8744 245530

E-mail: rm.kothagudem@beml.co.in

Leh

174-B, (Near Royal Enfield Showroom),
Housing Colony, Leh, Ladakh -194 101

T + 91 1982 258828 / 94198 71008

E-mail : mll@beml.co.in

Ramagundam

Near SCCL TTC, Jawahar Nagar,
Behind CISF Camp, Godavarikhani - 505 209.
Peddapalli Dist., Telangana

T + 91 8728 248299 / 94408 58441

E-mail: mhr@beml.co.in

Udaipur

20-B, Uchhab Bhavan, Bedla Road,
Fatehpura, Udaipur - 313 001.
Rajasthan

T + 91 294 2452054

E-mail: mwu@beml.co.in

Visakhapatnam

No. 8-45-11, 4th Lane,
Vidyanagar Chinna Waltair Colony
Visakhapatnam - 530 003, Andhra Pradesh

T/F + 91 891 2754608 / 83320 54590

E-mail : rm.vizag@beml.co.in

www.bemlindia.in

Represented by:



बी ई एम एल लिमिटेड BEML LIMITED

Schedule 'A' Company under Ministry of Defence, Govt. of India