

BD50_{HST}

CRAWLER DOZER

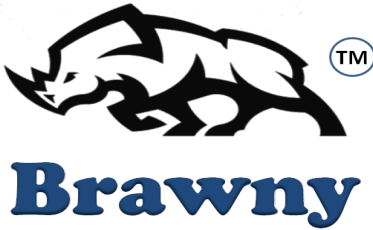

Salient Features :

- | BEML - BSAA4D105EG Electronic Governor Engine
- | Hydro-static Transmission
- | Arm Chair Steering Controls
- | Hydraulic Joy Stick Controls PAT blade operations
- | Adjustable Operator's Seat for excellent comfort
- | Integrated ROPS - FOPS Cabin
- | Advanced Electronic Monitoring System with colour display



BD50_{HST}

Flywheel horsepower : 75kW (100 hp) @ 2200 rpm
(As per ISO 9249)

Operating mass : 10,500 kg

www.bemlindia.in

BD50HST

CRAWLER DOZER

Salient Features :

- | BEML make Diesel Engine with Electronic Governor for sustained power and fuel economy.
- | Continuously variable Hydrostatic transmission for smooth dozing and travel.
- | High maneuverability with counter rotation of tracks to enable pivot steering.
- | Main frame and Track frame are of rigid welded Construction.
- | Job proven undercarriage.
- | Electronic proportional control joystick for Travel & Steering and Hydraulic joystick for PAT blade control ensure smooth & precise operation.
- | CLSS hydraulic system
- | Modular construction of engine, cooling system, pump and final drive for ease of serviceability and maintainability.
- | Lubricated Rollers and Idlers ensure reduced maintenance time and costs of undercarriage.
- | Track Link Dust seals prevent entry of abrasive dirt or mud and enables long track life.
- | Integral ROPS - FOPS Cabin with ergonomically located controls.
- | Tilttable Cabin for easy serviceability.
- | Adjustable Operator's seat for excellent comfort.
- | Advanced Electronic Monitoring System with colour display .
- | GPS system for remote tracking & GEO fencing
- | Trademark applied for: BRAUNY



ENGINE

Make	BEML
Model	BSAA4D105EG
Type	Water cooled, 4 cycle turbo charged, direct injection diesel engine
No. of Cylinders	4, inline
Bore x Stroke	i 105 x 125 mm
Displacement	4327 cc
Horse Power	
Flywheel power	75 kW (100 hp) @ 2200 rpm As per ISO: 9249
Maximum torque	48.2 kg-m @ 1200 rpm
Fuel System	
Type	Bosch inline FIP
Governor	Electronic
Lubrication system	
Method	Forced lubrication
Pump	Gear pump
Filter	Spin-on cartridge paper element
Oil Cooler	Water cooled
Cooling system	
Type	Centrifugal water pump & pusher type fan
Air Cleaner	
Type	Dry, horizontal type
Electricals	
Alternator	24 V, 45 A
Starting motor	24 V, 7.5 kW
Battery	2 x 12 V, 150 AH



POWER TRAIN

Hydrostatic Transmission

Dual-path, Hydrostatic Transmission provides infinite speed changes upto 8.5 kmph. The variable capacity travel motors allow the operator to select the optimum speed to match specific jobs using Travel control lever.

Final Drive

In-shoe mounted axial piston type Travel motors with integrated two stage planetary gear reduction. Compact in-shoe mount reduces risk of damage by debris. Bolt on sprocket ring.

Max. Drawbar pull	15,760 kg
-------------------	-----------

STANDARD ACCESSORIES

Hourmeter	Key switch
Ammeter	Back - up switch
Engine Oil Pressure Gauge	High water temperature indicator
Water temperature guage	Light switch
Head lamps & rear lamp	Low engine oil pressure indicator
Charger indicator	4st relay, battery relay
Back - up alarm	Tool kit
24 V, (12 V x 2) 150 Ah batteries	ROPS & FOPS Cabin

OPTIONAL ATTACHMENTS

500 mm shoe	Heater
Towing winch	Cold start kit
Multi - shank ripper	AC



HYDRAULIC SYSTEM

Hydraulic Pump Implement (Blade Control)

Capacity	40 ℓ / min @ 2200 rpm
Relief pressure	250 kg / cm ²

Hydraulic Cylinders

Cylinder	Qty	Bore x Stroke(mm)
Blade lift	2 cylinders	∅ 90 x 262 mm
Blade Angle	2 cylinders	∅ 90 x 444 mm
Blade tilt	1 cylinders	∅ 90 x 132 mm

STEERING

Electronic joystick control for all directional movements. Pushing the joystick forward results in forward machine travel. While pulling it rearward reverses the machine. Simply tilt the joystick to the left or right to make a turn. Tilting the joystick fully to the left or right activates counter rotation. The buttons provided on the joystick increase / decrease the speed.

Turning radius at rear tail corner - R 2124 mm

UNDER CARRIAGE

Suspension	Rigid type
Track Frame	Box section, high tensile strength steel construction
Track Rollers	6 No. each side
Carrier Rollers	2 No. each side
Track Shoes	
Type	Single grouser
Shoe width	460 mm
No. of shoes	42 each side
Ground pressure (Tractor only)	0.4 kg / cm ²
Gradeability	Longitudinal 30°

BLADE ATTACHMENT

	PAT Dozer
Overall length with dozer (mm) A	4550
Blade length x height (mm) B	2750 x 1000
Max. tilt adjustment (mm) C	372
Max. Drop below ground (mm) D	450
Max. lift above ground (mm) E	910
Overall Height (mm) F	2950
Grouser height (mm) G	50
Digging angle (degrees)	13.3

Mass (kg)	
Dozer attachment	1150

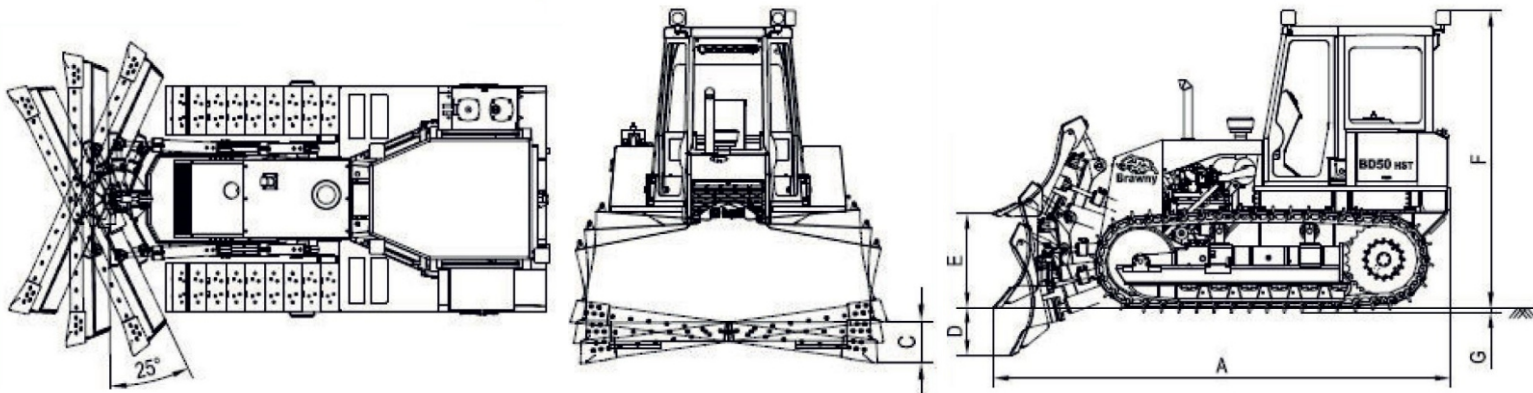

Ground Clearance : 400 mm

Material and specifications are subject to change without notice, Illustrations may include optional equipment & accessories

OPERATING MASS

Mass of tractor only (including rated capacity of lubricant, coolant and fuel)	9,350 kg
--	----------

COOLANT AND LUBRICANT CAPACITY (Refill)

System (refilling)	Capacity in ℓ
Cooling System	35
Engine oil pan	16
Fuel Tank	200
Final Drive (each side)	5
Hydraulic tank	65

DRAWBAR PULL Vs TRAVEL SPEED

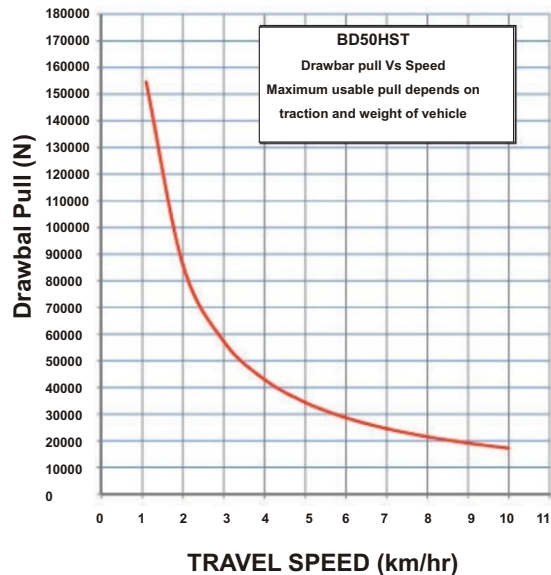

DIMENSIONS : in mm

बी ई एम एल लिमिटेड BEML LIMITED

Schedule 'A' Company under Ministry of Defence, Govt. of India

Business Network

Corporate Office

BEML Soudha, 23/1, 4th Main,
S.R. Nagar, Bangalore – 560 027

T + 91 80 22963240, 22963250

F + 91 80 22963278/516/280/164

E-mail: office.cpd@beml.co.in
corpcomm@beml.co.in

International Business Division

Flat No. E,F,G, H, 'Vandana' 11th Floor,
11, Tolstoy Marg, Connaught Place
New Delhi – 110 001

T + 91 11 23316500

F + 91 11 23325085

E-mail: mx@beml.co.in

Marketing Division

5th Floor, Unity Building,
J.C. Road, Bangalore – 560 002

T + 91 80 22963501/02/07/510/540

F + 91 80 22963541

E-mail: m@beml.co.in
mmd@beml.co.in

REGIONAL OFFICES

Bangalore

4th Floor, Unity Building, J. C. Road,
Bangalore - 560 002
Karnataka

T + 91 97413 51588

E-mail: mg@beml.co.in

Bilaspur

1-A, Industrial Area, Sector-C, Sirgitti,
Bilaspur - 495 223.
Chhattisgarh

T + 91 7752 252745, 252598

F + 91 7752 252065

E-mail: mv@beml.co.in

Neyveli

F-4, Dr. Rajendraprasad Road,
Block-27, Neyveli, - 607 803
Tamil Nadu

T/F + 91 4142 268517

T + 91 4142 265517 / 229392

E-mail: ma@beml.co.in

Dhanbad

Mouza - Kangalo, Amaghata,
Govindpur.KG Ashram Post, Dhanbad
Jharkhand – 828 109

T + 91 94711 92023

E-mail: mf@beml.co.in

Hyderabad

3-6-114, Street No.18, Himayat Nagar,
Hyderabad - 500 029
Telangana

T + 91 40 2322 7032 / 94907 93117

F + 91 40 23221794

E-mail: rm.hyderabad@beml.co.in

Kolkata

35/1A, Taratala Road,
Kolkata - 700 088.
West Bengal

T + 91 33 2401 5286 / 87 / 98 / 99

F + 91 33 2401 5288

E-mail: rm.kolkata@beml.co.in

Mumbai

32A, Bazar Road,
Near Jain Mandir, Bandra (West), Mumbai,
Maharashtra - 400 050

T + 91 22 26431875 / 26435875

F + 91 22 26423928

E-mail: rm.mumbai@beml.co.in

Nagpur

No 33, Cement Road,
Shivaji Nagar,
Nagpur - 440 010, Maharashtra.

T + 91 712 2248435 / 2248343

F + 91 712 2249997

E-mail: mn@beml.co.in

New Delhi

Flat E,F,G,H, 'Vandana', 11th Floor,
11, Tolstoy Marg, Connaught Place,
New Delhi - 110 001

T + 91 11 2344 3511 / 3528 / 2331 6500

F + 91 11 2332 5085

E-mail: ml@beml.co.in

Ranchi

206/D-1, Bhagirathi, (Behind NCC Campus)
Rameshwaram Colony, Bariatu Road,
Ranchi, Jharkhand - 834 009

T + 91 651 2540710 / 94311 08531

E-mail: mr@beml.co.in

Sambalpur

BEML Complex, NH-6, Panchagachhia,
Baraipalli Post, Sambalpur 768 006
Odisha.

T + 91 663 2521604 / 2521389

E-mail: mb@beml.co.in

Singrauli

PB No. 5, Jhingurdha Colliery,
Singrauli - 486 889
Madhya Pradesh.

T + 91 7805 272668 / 272318

F + 91 7805 272282

E-mail: rm.singrauli@beml.co.in

ACTIVITY CENTRES

Bhopal

Ground Floor, Hall No.1, Chittod Complex, Zone-1,
Maharanapratap Nagar (MP Nagar), Bhopal - 462 011

T + 91 755 2550711 / 8989459753

Panjim

BEML Limited, 5/4, Victor Building, Fontanhas, Mala,
Panjim - 403 001, Goa

T + 91 832 2225135 / 77986 87178

Itanagar

C/o. Tobom Riba, H-Sector, Papum
Itanagar – 791 113, Arunachal Pradesh

T + 91 94029 34205 / 88372 15852

Kochi

No. 39/2122, Chittoor Road, Emakulam South,
Kochi – 682 016

T + 91 484 2375138

E-mail: rm.kochi@beml.co.in

Maihar

Maihar, Madhya Pradesh

Mob: +91 79875 53768

Silapathar: Surya Vatika, Amritpur, Silapathar, Assam - 787 059 T + 91 95311 29059

DISTRICT OFFICES

Ahmedabad

99/100, BEML HOUSE, 2nd Street,
Azad Society, Ambawadi,
Ahmedabad - 380 015, Gujarat

T + 91 79 26445523 / 94264 13620

F + 91 79 26423950

E-mail: rm.ahmedabad@beml.co.in

Asansol

3, Bumpur Road,
Asansol - 713 304
West Bengal

T + 91 341 2252480

F + 91 341 2250601

E-mail: mca@beml.co.in

Bacheli

Behind Central Stores of NMDC Ltd.,
Depot 5, Bacheli - 494 553.
Chhattisgarh

T/F + 91 7857 230005

E-mail: rm.bacheli@beml.co.in

Bhilai

Room no 22/C, BSP Expansion Building,
Near Ispat Bhavan, Bhilai 490 001, Chhattisgarh

T + 91 788 2223880

F + 91 788 2221652

E-mail: mnb@beml.co.in

Bhubaneswar

252/A, Lewis Road
Bhubaneswar - 751 014
Odisha

T + 91 674 2434427 / 99373 83950

E-mail: mbb@beml.co.in

Chandrapur

Mamidwar, Tiles Factory Compound
Ghugus Road, Padoli
Chandrapur - 442 406 Maharashtra

T + 91 7172 287230

F + 91 7172 287560

E-mail: mnc@beml.co.in

Chennai

Flat No. 10, Supriya Estates,
No.3, Sterling Road, Nungambakkam,
Chennai - 600 034, Tamil Nadu,

T + 91 44 28220844

F + 91 44 28257319

E-mail: rm.chennai@beml.co.in

Guwahati

No.11, Ward 43, Hengrabari Road,
Ganesh Puri, Dispur,
Guwahati - 781 006 Assam

T + 91 361 2232966

F + 91 361 2232967

E-mail: rm.guwahati@beml.co.in

Hospet

No.1431, Manjunatha Complex,
Bhagat Singh Nagar, Opp. KSSIDC Indl. Estate,
Dam Road, Hospet - 583 203, Karnataka

T/F + 91 8394 230172

E-mail: rm.hospet@beml.co.in

Jammu

62C, Block D/C, Gandhi Nagar,
Jammu tawi - 180 004
Jammu and Kashmir

T + 91 191 2459 437

F + 91 191 2430 447

E-mail: mlj@beml.co.in

Kothagudem

Old Project Planning Department,
Near SCCL Corporate Office,
Kothagudem - 507 101, Telangana

T + 91 8744 245572

F + 91 8744 245530

E-mail: rm.kothagudem@beml.co.in

Leh

174-B, (Near Royal Enfield Showroom),
Housing Colony, Leh, Ladakh -194 101

T + 91 1982 258828 / 94198 71008

E-mail : mll@beml.co.in

Ramagundam

Near SCCL TTC, Jawahar Nagar,
Behind CISF Camp, Godavarikhani - 505 209.
Peddapalli Dist., Telangana

T + 91 8728 248299 / 94408 58441

E-mail: mhr@beml.co.in

Udaipur

20-B, Uchhab Bhavan, Bedla Road,
Fatehpura, Udaipur - 313 001.
Rajasthan

T + 91 294 2452054

E-mail: mwu@beml.co.in

Visakhapatnam

No. 8-45-11, 4th Lane,
Vidyanagar Chinna Waltair Colony
Visakhapatnam - 530 003, Andhra Pradesh

T/F + 91 891 2754608 / 83320 54590

E-mail : rm.vizag@beml.co.in

www.bemlindia.in

Represented by:



बी ई एम एल लिमिटेड BEML LIMITED

Schedule 'A' Company under Ministry of Defence, Govt. of India